



CUSTOMER CONVENIENCE

SERVING THE FOOD INDUSTRY SINCE 1951

TRASH RECEPTACLE FOR 36-GALLON BIN

Item: 43840

Omcan's trash receptacle with swing door provides the excellent compact solution for waste management. It is the perfect companion for restaurants, healthcare facilities, schools, offices, and hotels. Features an engraved message to reiterate the gratitude towards your customers as well as a recessed top for discarded food trays.



Authorized Dealer

FEATURES:

- Fits Standard 36 gallon / 136 litres bin
- Laminated melamine
- Hinged opening with engraved “thank you” message
- Food tray holder on top area
- Swing door for ease of cleaning

TECHNICAL SPECIFICATION

ITEM NUMBER	43840
MATERIAL	plywood / melamine
COLOR	Natural
NET WEIGHT	43KGS / 94.80 LBS
GROSS WEIGHT	45KGS / 99.20 LBS
DIMENSIONS (DWH)	22" x 47" x 22" / 558.80mm x 1193.80 x 558.80mm
PACKAGING DIMENSIONS	47" x 22" x 4.72" / 1200X570X120mm

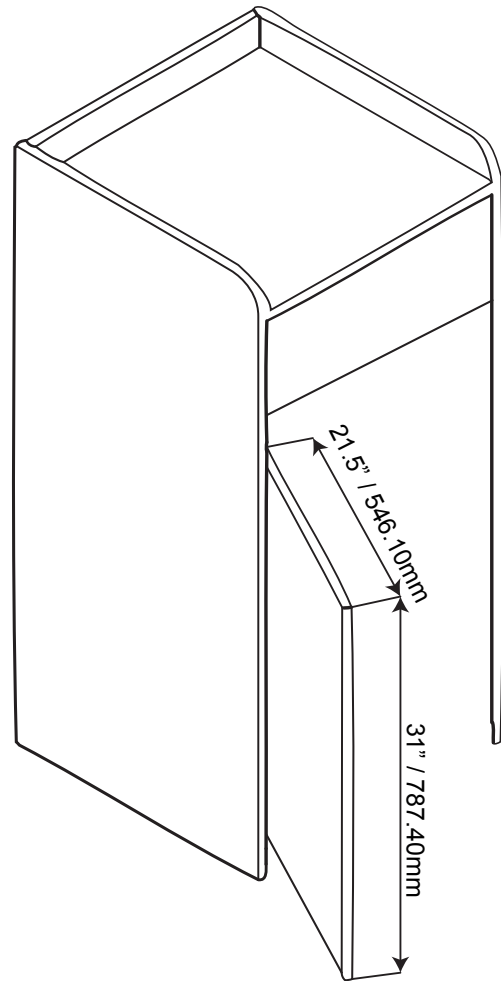
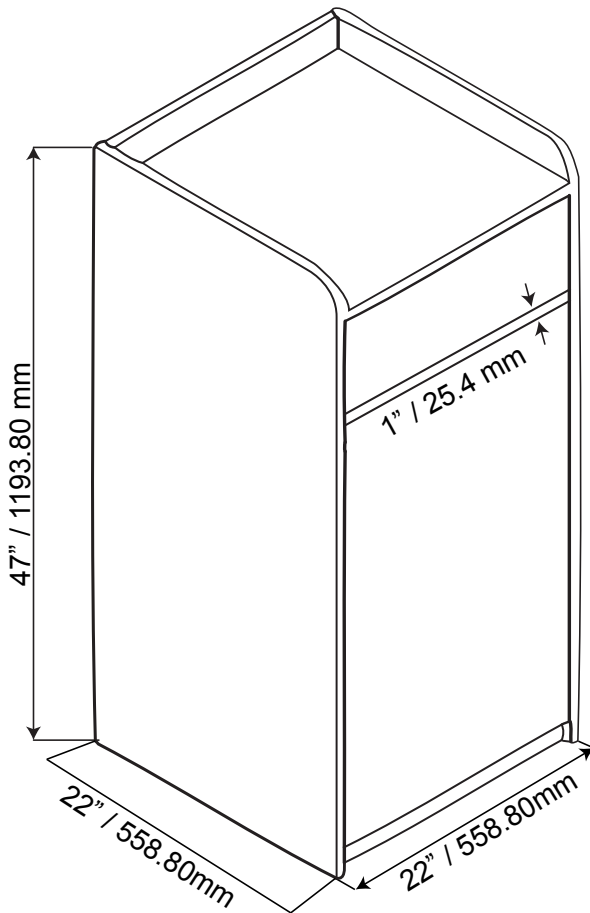

OMCAN INC.

Telephone: 1-800-465-0234
 Fax: (905) 607-0234
 Email: sales@omcan.com
 Website: www.omcan.com



Follow us to keep up to date with the latest news and offers

